

Twin City Fan & Blower

BULLETIN 355

July 2006

HIGH EFFICIENCY PLUG FANS

TYPE BEPL



BEPL High Efficiency Plug Fans

BEPL plug fans from Twin City Fan & Blower are compact, versatile and offer the highest efficiency in the industry. Their versatility allows them to be used for air circulation in a variety of industrial applications including air heaters, degreasers, dryers, dust collectors, kilns, ovens, parts washers, penthouses, smoke houses, space heaters, spray booths and other high temperature applications.

Plug fans are housed in the customer's enclosure in applications where the system plenum acts as the fan housing. This configuration saves space since connecting ductwork and motor support pedestals are generally not needed. More space savings can be obtained by utilizing the wheel compartment as a pressurized chamber in lieu of a fan scroll. The use of multiple discharges from the pressurized chamber allows for additional savings by reducing ducting requirements.



Class II w/4" Insulated Plug and High Temperature Aluminum Paint

Class II w/ OSHA Belt Guard

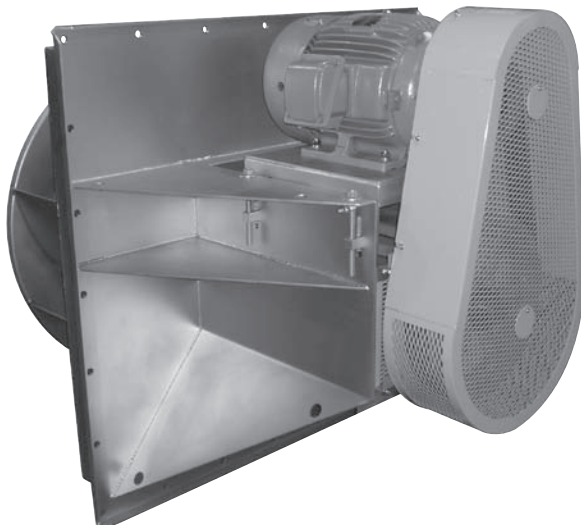

BEPL plug fans feature SWSI backward curved, non-overloading, single thickness airfoil type wheels. The unique wheel design offers increased efficiency over competitor's airfoil blade designs yet can handle airstreams not conducive to traditional hollow airfoil shapes.

The plug fan's motor and drive are protected from high temperatures by the customer's chamber wall or the optional 4" or 6" insulated plug. The motor and drive are mounted to the plug panel which may be bolted or welded in place. The plug assembly may be mounted with the shaft in either the vertical or horizontal position for maximum flexibility. Horizontal construction is standard. Vertical mounting can be provided when specified. An all welded housing and an integral inlet cone are available as options.

Performance Comparison

Type BEPL Plug Fans are designed to maximize efficiency. This is illustrated by the following charts, which compare the new BEPL Plug Fan and other manufacturers' airfoil (AF) and backward inclined (BI) fans.

Nominal 36" Wheel Diameter

CFM	SP	MANUFACTURER	RPM	BHP
23000	3.5"	Twin City BEPL	1015	15.43
		Manufacturer "A" AF	1107	16.60
		Manufacturer "A" BI	1005	17.50
		Manufacturer "B" AF	971	17.94
37000	5"	Twin City BEPL	1442	38.50
		Manufacturer "A" AF	1593	43.70
		Manufacturer "A" BI	1425	46.10
		Manufacturer "B" AF	1400	50.00

Nominal 44" Wheel Diameter

CFM	SP	MANUFACTURER	RPM	BHP
30000	2.5"	Twin City BEPL	716	14.40
		Manufacturer "A" AF	783	15.60
		Manufacturer "A" BI	713	16.50
		Manufacturer "B" AF	725	17.46
50000	5"	Twin City BEPL	1111	49.90
		Manufacturer "A" AF	1226	55.94
		Manufacturer "A" BI	1103	58.85
		Manufacturer "B" AF	1117	68.90

©2006 Twin City Fan & Blower. All rights reserved throughout the world.

Bulletin illustrations cover the general appearance of Twin City Fan & Blower products at the time of publication and we reserve the right to make changes in design and construction at any time without notice.

Construction Features

Plug Panel

Constructed of minimum 7-gauge steel with formed flanges to maintain flatness and rigidity. Panel is prepunched for bolt mounting. Panel assembly may also be welded in place. The “cross frame” bearing support is designed for maximum stability and load spreading. Bearings are serviceable without disassembly of panel or frame.

Plug Assembly

Available for both horizontal and vertical applications. Horizontal construction is standard. Vertical construction will be provided when specified.

Adjustable Motor Base

The motor base is standard with leveling and tension adjustment to ensure proper drive belt alignment. The motor base is heavy-gauge steel and prepunched to accept the standard motor frame specified.

Wheels

Wheels are assembled of die-formed, matched components, continuously welded to both back plate and rim. Wheels are statically and dynamically balanced.

Inlet Cones

Heavy-gauge and spun to match the wheel intake rim to insure smooth airflow. Inlet cone flange is prepunched for mounting. Inlet cones are shipped loose as standard. An integral inlet cone is optional.

Typical Installations

Mounting is accomplished by providing a hole larger than the wheel diameter through the chamber wall. The wheel, shaft, motor, and drive assembly is then positioned to the inlet cone (mounted in opposite wall) and secured in place. See Figure A.

Another method is to provide a hole sized only for the wheel drive shaft. The wheel is then positioned through the opening for the inlet cone after the drive and panel assembly has been securely mounted. See Figure B.

Plug fans may be applied with open wheel (unhoused) or with a housing as shown in Figure C. Performance data in this bulletin is for unhoused wheel application.

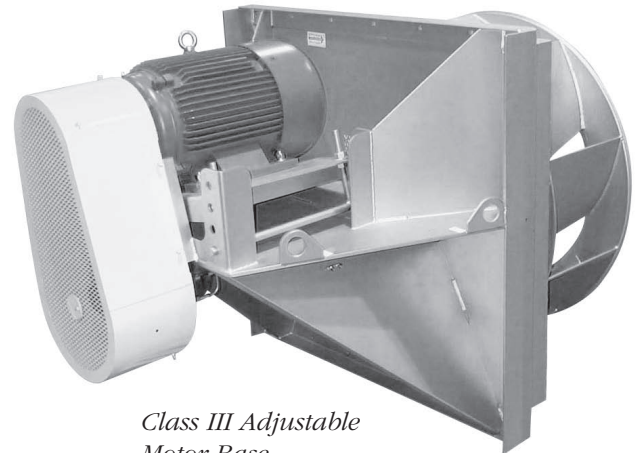

*Class III Adjustable
Motor Base*

Shafts

Shafts are AISI Grade 1040 or 1045 hot-rolled steel accurately turned, ground, polished and ring-gauged for verification. Shafts are sized for a first critical speed of at least 1.43 times the maximum speed of the class.

Bearings

Either ball or spherical roller, heavy duty, self-aligning, pillow block type bearings are provided. Bearing selection is based on L-10 minimum life of 40,000 hours or average life of 200,000 hours. Split roller bearings are not recommended.

Walls must be designed by the users to support the dynamic loads of the fan without resonance to eliminate vibration and bearing failure.

Plenum System

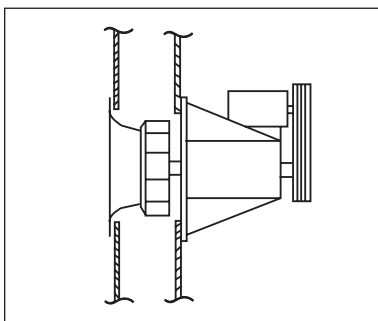
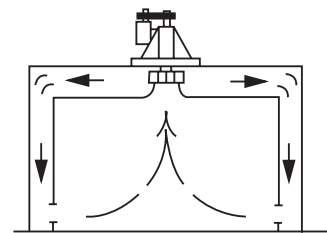

Figure A

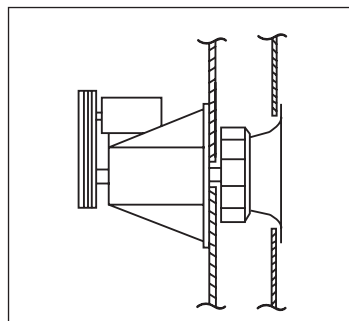

Figure B

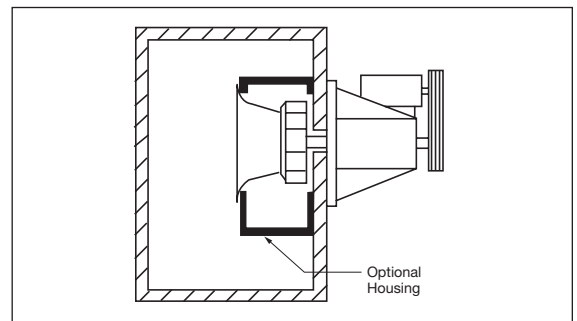

Figure C

Optional Construction

High Temperature Construction

301-500°F: Includes high temperature grease, expansion and non-expansion bearings, ceramic shaft seal and shaft cooler.

501-800°F: Includes the modifications above with the addition of high temperature aluminum paint. Minimum 4" insulation is required and is available as an optional item from TCF. Be sure to apply derating factors for high temperature construction. See Table 7 on page 6.

801-1000°F: Includes the modifications above with the addition of 316 stainless steel wheel and shaft. Also includes shaft extension for the required 6" insulation. 6" insulated plug is available as an optional item. Be sure to apply stainless steel derating factors for temperature. See Table 7 on page 6.

Insulated Plug

Protects motor and drive components from heat. An insulated plug is recommended for temperatures above 500°F. Available in 2", 4" and 6" thicknesses. Special thicknesses to match customer's insulated wall are available. Plug is assembled to mounting panel when ordered. See Table 1 on page 5 for maximum RPMs based on different thicknesses of the plug.

All Welded Housing

Heavy-gauge steel housing is provided with wheel opening on each side and weld studs on the inlet side for cone mounting. Specify rotation and discharge as viewed from drive side to insure proper stud placement. Housing supports and attachments for wall mounting to be provided by others. See page 14 for dimensions.

Variable Inlet Vanes

Vane blades are cantilever design or center supported, equipped with permanently lubricated bearings and ball joints for smooth and easy operation. Vane assemblies are external type for sizes 122 through 165 and nested for sizes 182 through 490. Standard inlet vanes are applicable to 300°F. Consult factory for higher temperatures.

Spark Resistant Construction

Fan applications may involve the handling of potentially explosive or flammable particles, fumes or vapors. Such applications require careful consideration by the system designer to insure the safe handling of such gases. Twin City Fan & Blower offers the following classifications of spark resistant construction per AMCA Standard 99-0401-86. It is the specifier or the user's responsibility to specify the type of spark resistant construction with full recognition of the potential hazards and the degree of protection required.

Type B - BEPL wheels employ high strength steel, therefore construction in aluminum must be reviewed by the factory for availability. The maximum temperature is not to exceed 200°F. Pricing available upon application review with substantial reduction in speed.

Type C - The fan shall be so constructed that a shift of the wheel or shaft will not permit two ferrous parts of the fan to rub or strike. This is accomplished by using a mild steel inlet cone with a Monel rub ring for temperatures up to 800°F. Consult factory for construction to 1000°F.

Integral Inlet Cone Assembly

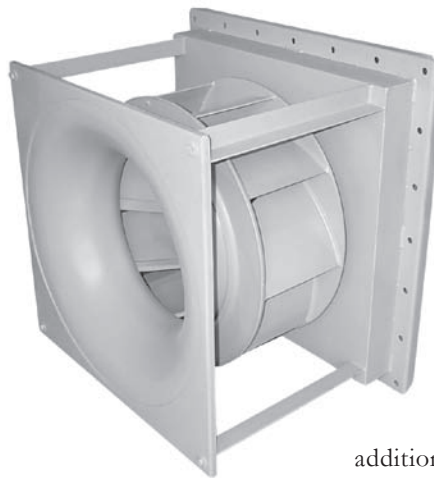

Includes four pieces of angle, welded to the insulated plug or mounting panel, which serve to pre-align the inlet funnel within the wheel. The entire unit can be installed or removed through the same hole in the customer's enclosure, without the need for additional mounting or alignment of the inlet cone.

Mounting Arrangements

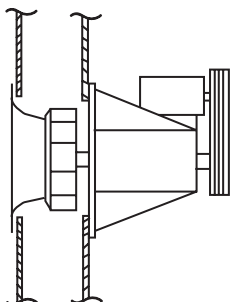

Horizontal

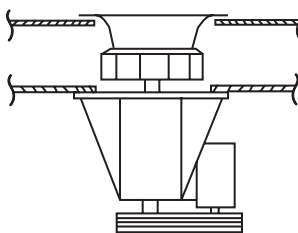

Vertical Up

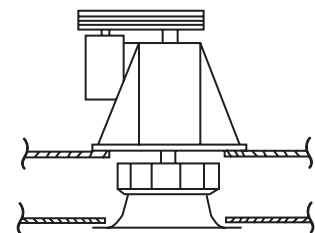

Vertical Down

Engineering Data

To ensure proper motor selection, consideration must be given to starting torque requirements (fan wheel inertia WR^2) along with the operating BHP. Table 1 lists the WR^2 factors for different wheel sizes to be used in evaluating the capability of

a selected motor. In some cases it may be necessary to provide a larger horsepower motor, even though it may not be dictated by the operating BHP, to bring the fan to speed.

Table 1. Maximum Fan RPMs, Wheel Weights and WR^2 (refer to Table 7 for derates at elevated temperatures)

FAN SIZE	CLASS II					CLASS III				
	MAXIMUM RPM			WHEEL WT. (LBS.)	WR^2 (LBS-FT ²)	MAXIMUM RPM			WHEEL WT. (LBS.)	WR^2 (LBS-FT ²)
	NO PLUG	4" PLUG	6" PLUG			NO PLUG	4" PLUG	6" PLUG		
122	3777	3777	3000	21	3	-	-	-	-	-
150	3352	3352	2875	24	4	-	-	-	-	-
165	2975	2975	2425	32	7	-	-	-	-	-
182	2566	2566	2566	37	12	3453	3453	3230	46	12
200	2341	2341	2341	42	17	3151	3151	2965	52	17
222	2105	2105	1905	67	28	2833	2833	2833	78	29
245	1911	1911	1765	79	42	2572	2572	2435	98	49
270	1734	1734	1734	105	64	2334	2334	2334	111	70
300	1561	1561	1561	119	93	2101	2101	2101	139	116
330	1419	1419	1419	136	134	1910	1910	1910	165	155
365	1283	1283	1283	175	226	1727	1727	1550	211	264
402	1163	1163	1163	204	330	1566	1566	1566	245	385
445	1052	1052	1052	334	542	1416	1416	1416	367	621
490	956	956	956	377	772	1286	1286	1286	458	1015

Table 2. Bare Fan and Accessory Weights

FAN SIZE	APPROXIMATE WEIGHTS (LBS.)				
	BARE FAN		INSULATED PLUG	HOUSING	INLET VANES
	CLASS II	CLASS III			
122	140	-	25	24	45
150	145	-	25	30	52
165	185	-	32	44	58
182	230	428	32	65	29
200	233	452	32	79	33
222	247	507	35	97	38
245	252	581	35	117	40
270	341	711	40	143	45
300	348	756	40	236	45
330	376	960	55	287	50
365	438	1093	55	350	50
402	586	1427	75	428	55
445	652	1630	75	522	60
490	962	1745	95	634	65

Table 3. High Temperature Applications

TEMP. RANGE	BEARING TYPE	LUBRICATION	OTHER REQUIREMENTS
TO 300°F	BALL OR ROLLER	GREASE	STANDARD CONSTRUCTION
301 TO 500°F	EXPANSION AND NON-EXPANSION	HIGH TEMPERATURE GREASE	CERAMIC SHAFT SEAL, SHAFT COOLER
501 TO 800°F	EXPANSION AND NON-EXPANSION	HIGH TEMPERATURE GREASE	HIGH TEMPERATURE ALUMINUM PAINT 4" MINIMUM INSULATION REQUIRED BY TCF OR CUSTOMER CERAMIC SHAFT SEAL, SHAFT COOLER
801 TO 1000°F	EXPANSION AND NON-EXPANSION	HIGH TEMPERATURE GREASE	316 STAINLESS STEEL WHEEL AND SHAFT 6" MINIMUM INSULATION REQUIRED BY TCF OR CUSTOMER HIGH TEMPERATURE ALUMINUM PAINT CERAMIC SHAFT SEAL, SHAFT COOLER

Engineering Data

Figure 1. Wheel and Plenum Arrangement

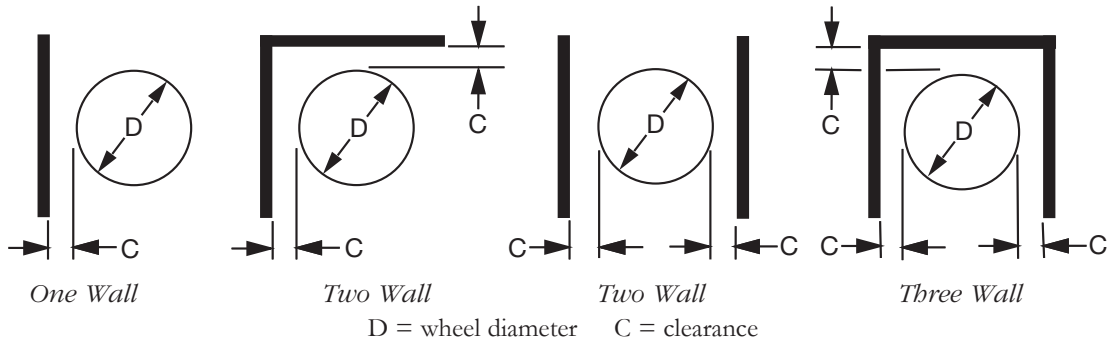

Table 4. Wall Proximity Factors

% WOV	FACTOR	C = D/8			C = D/4			C = D/2		
		ONE WALL	TWO WALL	THREE WALL	ONE WALL	TWO WALL	THREE WALL	ONE WALL	TWO WALL	THREE WALL
95	RPM	1.02	1.03	1.09	1.01	1.02	1.06	1.01	1.01	1.03
	BHP	1.06	1.08	1.29	1.04	1.06	1.20	1.02	1.02	1.08
85	RPM	1.02	1.02	1.08	1.01	1.02	1.06	1.01	1.01	1.03
	BHP	1.05	1.07	1.26	1.03	1.05	1.18	1.02	1.02	1.08
75	RPM	1.01	1.02	1.07	1.01	1.02	1.05	1.00	1.01	1.02
	BHP	1.04	1.06	1.23	1.03	1.05	1.16	1.01	1.02	1.07
65	RPM	1.01	1.02	1.06	1.01	1.01	1.04	1.00	1.01	1.02
	BHP	1.04	1.06	1.19	1.03	1.04	1.14	1.01	1.02	1.06
55	RPM	1.01	1.02	1.05	1.01	1.01	1.04	1.00	1.01	1.02
	BHP	1.03	1.05	1.16	1.02	1.03	1.12	1.01	1.02	1.05
45	RPM	1.01	1.01	1.04	1.01	1.01	1.03	1.00	1.00	1.01
	BHP	1.02	1.04	1.13	1.02	1.03	1.09	1.01	1.01	1.04

Table 5. WOV Factors

SIZE	WOV FACTOR	D
122	1.04	12.40
150	1.92	13.98
165	2.55	15.75
182	3.65	18.25
200	4.81	20.00
222	6.81	22.25
245	9.09	24.50
270	12.63	27.00
300	17.32	30.00
330	23.05	33.00
365	30.62	36.50
402	41.06	40.25
445	55.49	44.50
490	74.09	49.00

Table 6. Temperature and Altitude Correction Factors

AIR TEMP °F	ALTITUDE IN FEET ABOVE SEA LEVEL											
	0	1000	2000	3000	4000	5000	6000	7000	8000	9000	10000	15000
	BAROMETRIC PRESSURE IN INCHES OF MERCURY											
	29.92	28.86	27.82	26.82	25.84	24.90	23.98	23.09	22.22	21.39	20.58	16.89
70	1.000	0.964	0.930	0.896	0.864	0.832	0.801	0.772	0.743	0.714	0.688	0.564
100	0.946	0.912	0.880	0.848	0.818	0.787	0.758	0.730	0.703	0.676	0.651	0.534
150	0.869	0.838	0.808	0.770	0.751	0.723	0.696	0.671	0.646	0.620	0.598	0.490
200	0.803	0.774	0.747	0.720	0.694	0.668	0.643	0.620	0.596	0.573	0.552	0.453
250	0.747	0.720	0.694	0.669	0.645	0.622	0.598	0.576	0.555	0.533	0.514	0.421
300	0.697	0.672	0.648	0.624	0.604	0.580	0.558	0.538	0.518	0.498	0.480	0.393
400	0.616	0.594	0.573	0.552	0.532	0.513	0.493	0.476	0.458	0.440	0.424	0.347
500	0.552	0.532	0.513	0.495	0.477	0.459	0.442	0.426	0.410	0.394	0.380	0.311
600	0.500	0.482	0.469	0.448	0.432	0.416	0.400	0.386	0.372	0.352	0.344	0.282
700	0.457	0.441	0.425	0.410	0.395	0.380	0.366	0.353	0.340	0.326	0.315	0.258
800	0.420	0.404	0.389	0.375	0.362	0.350	0.336	0.323	0.311	0.300	0.290	0.237
900	0.389	0.376	0.363	0.349	0.336	0.324	0.312	0.300	0.289	0.279	0.268	0.220
1000	0.363	0.350	0.338	0.325	0.314	0.302	0.291	0.280	0.270	0.259	0.250	0.205

Table 7. Derate Values

TEMP	STEEL	304/ 316 SS
70	1	1
200	0.97	0.95
300	0.94	0.92
400	0.92	0.88
500	0.92	0.84
600	0.91	0.81
700	0.89	0.78
800	0.86	0.75
900	NA	0.73
1000	NA	0.70

NOTE: For aluminum construction, consult factory for maximum speeds.

Plug Fan Selection

The performance tables in this catalog are based on fans handling standard air at a density of 0.075 pounds per cubic foot. This is equivalent to air at 70°F at sea level (29.92 Hg barometric pressure). When specified performance is at a density different than standard, it must be converted to the equivalent standard conditions before the fan can be selected from the performance tables. The performance data and examples in this catalog are for unhooused BEPL plug fans.

Example 1. Standard Density

Given: 17000 CFM at 3" TSP (system). Installation is a two-wall arrangement with a wheel-to-wall clearance of 6.75".

Step 1. Entering the performance tables we find that a 270 BEPL plug fan will deliver 17000 CFM at 3" SP operating at 1652 RPM with 12.21 BHP.

Step 2. Catalog performance must be corrected for wheel-to-wall arrangement. Determine the wheel and plenum type from the arrangements shown in Figure 1 on page 6. Determine the clearance "C" based upon the closest wall. Performance will not be affected by any additional walls spaced greater than C x 3 from the wheel.

The selected 270 BEPL fan has a wheel diameter of 27.0" ("D"). Application is two walls with 6.75" clearance ("C"). Therefore, C ÷ D = 6.75 ÷ 27.0 = 0.25 or 1/4" which is equivalent to D ÷ 4.

Step 3. Next, determine the Percent of Wide Open Volume (% WOV) at which the fan is to operate. From Table 5 on page 6 find that the WOV factor is 12.63 for a 270 BEPL fan.

$$\% \text{ WOV} = \frac{17000 \times 100}{1652 \times 12.63} = 81.5$$

Step 4. By interpolation from Table 4 on page 6, for the two wall column of D ÷ 4 at 81.5% WOV, we find the RPM factor of 1.02 and the BHP factor of 1.05.

Corrected unhooused performance for 17000 CFM at 3" SP standard air is:

$$\text{RPM} = 1652 \times 1.02 = 1685$$

$$\text{BHP} = 12.21 \times 1.05 = 12.82$$

Example 2. Nonstandard Density

Given: 17000 CFM at 3" TSP (system), 300°F, 4000 ft. altitude. Installation is a two-wall arrangement with a wheel-to-wall clearance of 6.75".

Step 1. To enter the performance tables the operating SP must be corrected to equivalent standard conditions. From Table 6 on page 6 find the correction factor of 0.604 for 300°F and 4000 feet altitude. The corrected equivalent static pressure is equal to:

$$\text{SP (Catalog)} = \frac{3" \text{ TSP (system)}}{0.604} = 5.0$$

Fan selection is then made for 17000 CFM at 5" SP. Entering the performance tables, we find that a 270 BEPL fan will deliver 17000 CFM at 1805 RPM with 17.75 BHP. It must be remembered that this BHP is cataloged at standard 70°F air at sea level.

Steps 2, 3, & 4. Continue the correction procedure with Steps 2, 3 and 4 as shown in Example 1. Wall arrangement = D ÷ 4, % WOV = 74.6, RPM = 1841, and BHP = 18.64.

Performance Data

122 BEPL

Wheel Dia.: 12.40"

Max. BHP = 0.059 x (RPM ÷ 1000)³

CFM	0.5" SP		1" SP		1.5" SP		2" SP		2.5" SP		3" SP		3.5" SP		4" SP		4.5" SP		5" SP		5.5" SP		6" SP	
	RPM	BHP	RPM	BHP	RPM	BHP	RPM	BHP	RPM	BHP	RPM	BHP	RPM	BHP	RPM	BHP	RPM	BHP	RPM	BHP	RPM	BHP	RPM	BHP
700	1155	0.09																						
800	<u>1201</u>	<u>0.10</u>	1563	0.23																				
900	<u>1261</u>	<u>0.11</u>	1602	0.24																				
1000	1327	0.13	1637	0.26	1923	0.42																		
1200	1473	0.17	<u>1738</u>	<u>0.30</u>	1996	0.47	2239	0.66																
1400	1627	0.22	1868	0.35	<u>2087</u>	<u>0.52</u>	2309	0.72	2525	0.95	2713	1.18												
1600	1784	0.29	2010	0.43	2211	0.60	<u>2401</u>	<u>0.79</u>	2595	1.02	2789	1.28	2966	1.54	3126	1.81								
1800	1945	0.38	2161	0.53	2346	0.70	<u>2522</u>	<u>0.89</u>	<u>2691</u>	<u>1.11</u>	2862	1.36	3037	1.64	3205	1.94	3358	2.24	3500	2.54				
2000	2109	0.48	2316	0.64	2492	0.82	2655	1.02	<u>2812</u>	<u>1.24</u>	<u>2964</u>	<u>1.48</u>	3116	1.75	3273	2.05	3430	2.37	3578	2.70	3716	3.03		
2200	2276	0.60	2473	0.78	2643	0.97	2796	1.17	2944	1.39	<u>3086</u>	<u>1.64</u>	<u>3224</u>	<u>1.90</u>	<u>3362</u>	<u>2.19</u>	3503	2.50	3647	2.84				
2400	2444	0.74	2633	0.93	2798	1.14	2945	1.35	3083	1.57	3218	1.82	<u>3348</u>	<u>2.08</u>	<u>3476</u>	<u>2.37</u>	<u>3602</u>	<u>2.68</u>	3729	3.00				
2600	2615	0.91	2795	1.12	2954	1.33	3098	1.55	3230	1.78	3356	2.03	3481	2.30	<u>3602</u>	<u>2.59</u>	3720	2.89						
2800	2787	1.09	2959	1.32	3113	1.55	3253	1.78	3382	2.03	3502	2.28	3619	2.55	3735	2.84								
3000	2960	1.31	3125	1.55	3273	1.79	3410	2.04	3536	2.30	3653	2.56	3765	2.84										
3200	3134	1.55	3293	1.81	3436	2.07	3568	2.33	3692	2.60														
3400	3310	1.83	3462	2.11	3600	2.38	3728	2.65																
3600	3486	2.13	3632	2.43	3766	2.72																		
3800	3663	2.47																						
4000																								

Maximum RPM @ 70°F:

Class II — 3777

Must derate for temperature and plug wall thickness.

Underlined figures indicate maximum static efficiency.

Power rating (BHP) does not include transmission losses.

Performance Data

150 BEPL

Wheel Dia.: 13.98"

Max. BHP = 0.108 x (RPM ÷ 1000)³

CFM	0.5" SP		1" SP		1.5" SP		2" SP		2.5" SP		3" SP		3.5" SP		4" SP		4.5" SP		5" SP		5.5" SP		6" SP	
	RPM	BHP	RPM	BHP	RPM	BHP	RPM	BHP	RPM	BHP	RPM	BHP	RPM	BHP	RPM	BHP	RPM	BHP	RPM	BHP	RPM	BHP	RPM	BHP
900	1027	0.12																						
1000	1058	0.12	1381	0.28																				
1200	1144	0.15	1434	0.32																				
1400	1241	0.19	1492	0.35	1740	0.57	1950	0.80																
1600	1346	0.23	1574	0.40	1790	0.61	2005	0.87	2190	1.13														
1800	1454	0.29	1666	0.46	1860	0.67	2054	0.92	2245	1.22	2413	1.51												
2000	1564	0.36	1765	0.53	1946	0.75	2117	0.99	2293	1.28	2466	1.61	2622	1.94	2763	2.27								
2200	1675	0.44	1870	0.63	2039	0.84	2198	1.09	2354	1.37	2514	1.69	2673	2.05	2820	2.41	2953	2.77	3079	3.14				
2400	1789	0.53	1977	0.73	2137	0.95	2288	1.20	2432	1.48	2575	1.79	2722	2.14	2869	2.53	3008	2.93	3136	3.32	3256	3.72		
2600	1904	0.64	2086	0.85	2240	1.08	2383	1.33	2520	1.62	2652	1.93	2784	2.27	2919	2.64	3056	3.05	3188	3.48	3312	3.91		
2800	2021	0.76	2196	0.99	2347	1.23	2482	1.49	2613	1.77	2739	2.08	2861	2.42	2983	2.78	3108	3.18	3235	3.61				
3000	2138	0.90	2307	1.15	2455	1.40	2586	1.66	2709	1.95	2831	2.26	2947	2.60	3062	2.97	3175	3.35	3291	3.77				
3200	2257	1.06	2420	1.32	2563	1.58	2692	1.86	2811	2.15	2926	2.47	3039	2.81	3148	3.17	3255	3.56						
3400	2376	1.24	2534	1.51	2673	1.79	2800	2.08	2915	2.38	3025	2.70	3133	3.04	3239	3.40	3341	3.79						
3800	2617	1.65	2764	1.96	2896	2.26	3017	2.58	3129	2.90	3233	3.24	3333	3.59										
4200	2861	2.15	2999	2.49	3123	2.83	3239	3.17	3347	3.52														
4600	3107	2.75	3236	3.13																				
5000																								
5400																								

Maximum RPM @ 70°F:

Class II — 3352

Must derate for temperature and plug wall thickness.

165 BEPL

Wheel Dia.: 15.75"

Max. BHP = 0.196 x (RPM ÷ 1000)³

CFM	0.5" SP		1" SP		1.5" SP		2" SP		2.5" SP		3" SP		3.5" SP		4" SP		4.5" SP		5" SP		5.5" SP		6" SP	
	RPM	BHP	RPM	BHP	RPM	BHP	RPM	BHP	RPM	BHP	RPM	BHP	RPM	BHP	RPM	BHP	RPM	BHP	RPM	BHP	RPM	BHP	RPM	BHP
1200	923	0.15																						
1400	977	0.17	1252	0.38																				
1600	1041	0.20	1286	0.41	1511	0.67																		
1800	1110	0.24	1330	0.45	1549	0.72	1735	1.02																
2000	1183	0.29	1387	0.49	1583	0.77	1775	1.09	1937	1.42														
2200	1258	0.34	1451	0.55	1628	0.82	1808	1.15	1977	1.51	2124	1.87												
2400	1335	0.41	1518	0.62	1684	0.89	1846	1.21	2012	1.58	2164	1.98	2299	2.38										
2600	1412	0.48	1589	0.70	1747	0.97	1896	1.29	2047	1.65	2199	2.07	2339	2.50	2465	2.93								
2800	1490	0.56	1663	0.80	1812	1.07	1953	1.38	2091	1.74	2233	2.15	2374	2.61	2504	3.07	2623	3.53	2734	3.99				
3000	1570	0.65	1738	0.90	1880	1.18	2016	1.50	2145	1.85	2274	2.25	2407	2.70	2539	3.19	2662	3.68	2775	4.18	2881	4.68		
3400	1731	0.87	1890	1.15	2025	1.44	2149	1.77	2269	2.13	2384	2.52	2497	2.95	2611	3.41	2729	3.93	2846	4.48	2957	5.04		
3800	1895	1.14	2045	1.45	2176	1.77	2292	2.10	2402	2.47	2510	2.86	2614	3.30	2715	3.75	2817	4.25	2919	4.77				
4200	2061	1.47	2203	1.81	2328	2.15	2441	2.51	2545	2.89	2644	3.28	2742	3.72	2837	4.18	2930	4.67						
4600	2229	1.85	2363	2.22	2483	2.59	2593	2.98	2694	3.38	2788	3.79	2878	4.22	2968	4.69								
5000	2398	2.30	2526	2.71	2641	3.11	2746	3.52	2845	3.95	2936	4.38												
5400	2569	2.82	2690	3.27	2800	3.70	2902	4.14																
5800	2741	3.42	2856	3.90	2962	4.38																		
6200	2914	4.11																						
6600																								

Maximum RPM @ 70°F:

Class II — 2975

Must derate for temperature and plug wall thickness.

182 BEPL

Wheel Dia.: 18.25"

Max. BHP = 0.444 x (RPM ÷ 1000)³

CFM	1" SP		2" SP		3" SP		4" SP		5" SP		6" SP		7" SP		8" SP		9" SP		10" SP		11" SP		12" SP	
	RPM	BHP	RPM	BHP	RPM	BHP	RPM	BHP	RPM	BHP	RPM	BHP	RPM	BHP	RPM	BHP	RPM	BHP	RPM	BHP	RPM	BHP	RPM	BHP
2000	1047	0.49																						
2500	1078	0.56	1468	1.28																				
3000	1153	0.65	1485	1.42																				
3500	1258	0.79	1521	1.56	1814	2.55	2075	3.61																
4000	1371	0.96	1588	1.73	1836	2.74	2093	3.90	2323	5.11														
4500	1485	1.15	1683	1.98	1888	2.97	2111	4.15	2341	5.48	2549	6.83												
5000	1602	1.37	1791	2.27	1962	3.25	2157	4.45	2359	5.79	2566	7.25	2759	8.76	2936	10.27								
5500	1722	1.63	1903	2.60	2058	3.62	2221	4.78	2402	6.15	2585	7.62	2775	9.23	2956	10.88	3122	12.54						
6000	1845	1.92	2016	2.96	2166	4.05	2307	5.21	2462	6.55	2629	8.06	2796	9.66	2970	11.40	3140	13.18	3299	14.99	3448	16.79		
6500	1969	2.25	2132	3.37	2278	4.54	2408	5.73	2541	7.05	2687	8.53	2841	10.17	2996	11.91	3154	13.73	3314	15.66				
7000	2094	2.62	2249	3.82	2390	5.05	2517	6.33	2637	7.66	2763	9.11	2899	10.72	3043	12.49	3186	14.34	3332	16.28				
7500	2221	3.04	2369	4.31	2504	5.62	2629	6.97	2742	8.35	2854	9.79	2974	11.38	3102	13.13	3235	15.00	3370	16.98				
8000	2348	3.50	2490	4.86	2620	6.24	2741	7.66	2853	9.12	2958	10.61	3063	12.17	3176	13.87	3296	15.73	3421	17.72				
8500	2477	4.02	2612	5.45	2737	6.91	2855	8.40	2965	9.94	3066	11.48	3165	13.09	3265	14.77	3371	16.58						
9000	2606	4.59	2736	6.10	2857	7.64	2970	9.2																

Performance Data

200 BEPL

Wheel Dia.: 20.00"

Max. BHP = 0.701 x (RPM ÷ 1000)³

CFM	1" SP		2" SP		3" SP		4" SP		5" SP		6" SP		7" SP		8" SP		9" SP		10" SP		11" SP		12" SP	
	RPM	BHP	RPM	BHP	RPM	BHP	RPM	BHP	RPM	BHP	RPM	BHP	RPM	BHP	RPM	BHP	RPM	BHP	RPM	BHP	RPM	BHP	RPM	BHP
2500	957	0.60																						
3000	984	0.67																						
3500	1038	0.76																						
4000	1114	0.89																						
4500	1199	1.05																						
5000	1284	1.22	1339	1.54																				
5500	1372	1.42	1353	1.69																				
6000	1461	1.65	1373	1.81	1650	2.98																		
6500	1552	1.90	1415	1.97	1662	3.18	1902	4.52																
7000	1645	2.18	1475	2.17	1689	3.38	1914	4.79	2126	6.30														
7500	1738	2.49	1491	2.43	1732	3.61	1932	5.04	2138	6.64	2329	8.29												
8000	1833	2.84	1551	2.43	1790	3.90	1968	5.34	2152	6.95	2342	8.71	2518	10.52	2679	12.32								
8500	1929	3.23	1633	2.72	1862	4.26	2015	5.66	2184	7.31	2355	9.08	2530	10.99	2694	12.94	2845	14.90						
9000	2025	3.65	1804	3.40	1942	4.68	2076	6.07	2226	7.69	2383	9.49	2542	11.41	2705	13.47	2861	15.59	3004	17.69	3140	19.80		
9500	2119	4.01	1879	3.79	2026	5.14	2149	6.56	2280	8.14	2423	9.95	2570	11.90	2719	13.97	2871	16.17	3018	18.41				
10000	2219	4.61	1929	4.21	2111	5.64	2229	7.11	2345	8.68	2472	10.45	2608	12.42	2746	14.52	2885	16.71	3028	19.04				
11000	2416	5.75	2069	4.67	2197	6.17	2312	7.71	2420	9.31	2533	11.05	2655	12.99	2784	15.11	2914	17.35	3044	19.66				
12000	2614	7.08	2160	5.17	2284	6.74	2397	8.36	2501	10.01	2604	11.76	2713	13.66	2830	15.76	2952	18.02	3074	20.37				
13000	2814	8.64	2345	6.30	2460	8.00	2569	9.78	2670	11.59	2763	13.41	2855	15.32	2950	17.35	3051	19.54						
14000	3015	10.42	2533	7.60	2641	9.46	2744	11.37	2841	13.33	2932	15.31	3018	17.33	3101	19.39								
			2723	9.09	2826	11.12	2923	13.18	3015	15.27	3103	17.40												
			2916	10.80	3013	12.99	3105	15.21																
			3111	12.74																				

Maximum RPM @ 70°F:

Class II — 2341

Class III — 3151

Must derate for temperature and plug wall thickness.

222 BEPL

Wheel Dia.: 22.25"

Max. BHP = 1.20 x (RPM ÷ 1000)³

CFM	1" SP		2" SP		3" SP		4" SP		5" SP		6" SP		7" SP		8" SP		9" SP		10" SP		11" SP		12" SP	
	RPM	BHP	RPM	BHP	RPM	BHP	RPM	BHP	RPM	BHP	RPM	BHP	RPM	BHP	RPM	BHP	RPM	BHP	RPM	BHP	RPM	BHP	RPM	BHP
3000	842	0.71																						
3500	859	0.76																						
4000	892	0.84																						
4500	937	0.94																						
5000	990	1.06																						
5500	1048	1.20																						
6000	1108	1.36	1185	1.93																				
7000	1233	1.73	1197	2.05																				
8000	1364	2.19	1217	2.17	1454	3.59																		
9000	1498	2.74	1250	2.32	1465	3.76	1673	5.39																
10000	1632	3.38	1291	2.51	1484	3.93	1684	5.64	1868	7.43														
11000	1768	4.13	1392	2.96	1551	4.41	1718	6.09	1889	8.03	2055	10.12	2209	12.21										
12000	1905	4.99	1508	3.53	1643	5.03	1785	6.73	1930	8.63	2079	10.77	2229	13.11	2371	15.49	2506	17.88						
13000	2043	5.98	1629	4.19	1753	5.79	1874	7.53	2000	9.46	2129	11.57	2259	13.85	2394	16.39	2526	19.04	2652	21.71	2773	24.41		
14000	2182	7.10	1757	4.98	1871	6.67	1980	8.49	2089	10.46	2202	12.58	2318	14.88	2435	17.34	2553	19.98	2674	22.82	2794	25.79		
15000	2322	8.37	1888	5.89	1993	7.68	2095	9.60	2194	11.64	2293	13.81	2395	16.12	2500	18.60	2606	21.22	2712	23.97	2821	26.94		
16000	2462	9.79	2020	6.91	2120	8.84	2215	10.85	2308	12.99	2397	15.21	2488	17.57	2582	20.09	2677	22.71	2774	25.50				
17000	2603	11.39	2155	8.08	2250	10.14	2338	12.25	2426	14.49	2511	16.82	2594	19.25	2677	21.78	2763	24.46						
18000	2745	13.17	2289	9.37	2382	11.60	2466	13.83	2548	16.16	2629	18.60	2707	21.11	2784	23.72								
			2425	10.81	2515	13.21	2596	15.58	2673	18.01	2750	20.55	2825	23.17										
			2561	12.40	2649	14.98	2728	17.51	2802	20.07														
			2698	14.16	2784	16.92																		

Maximum RPM @ 70°F:

Class II — 2105

Class III — 2833

Must derate for temperature and plug wall thickness.

245 BEPL

Wheel Dia.: 24.50"

Max. BHP = 1.95 x (RPM ÷ 1000)³

CFM	1" SP		2" SP		3" SP		4" SP		5" SP		6" SP		7" SP		8" SP		9" SP		10" SP		11" SP		12" SP	
	RPM	BHP	RPM	BHP	RPM	BHP	RPM	BHP	RPM	BHP	RPM	BHP	RPM	BHP	RPM	BHP	RPM	BHP	RPM	BHP	RPM	BHP	RPM	BHP
4000	772	0.89																						
5000	820	1.079																						
6000	894	1.27																						
7000	981	1.56																						
8000	1073	1.90																						
9000	1170	2.32	2.38																					
10000	1269	2.81	1103	2.61	1320	4.34																		
11000	1369	3.37	1155	2.94	1339	4.67	1525	6.71																
12000	1470	4.02	1225	3.36	1381	5.09	1544	7.15	1708	9.49	1859	11.87												
13000	1571	4.74	1308	3.87	1442	5.65	1583	7.69	1727	10.01	1875	12.63	2013	15.30	2144	18.00								
14000	1674	5.56	1396	4.46	1516	6.31	1639	8.38	1767	10.70	1896	13.25	2029	16.10	2158	19.07	2279	22.04						
15000	1777	6.48	1488	5.15	1600	7.09	1708	9.20	1822	11.56	1938	14.11	2055	16.88	2176	19.95	2296	23.19	2410	26.44	2519	29.71		
16000	1880	7.50	1583	5.92	1688	7.97	1788	10.17	1888	12.54	1992	15.12	2099	17.91	2206	20.88	2315	24.09	2427	27.58	2535	31.11		
17000	1984	8.63	1681	6.81	1779	8.96	1873	11.25	1965	13.70	2058	16.31	2154	19.10	2253	22.11	2351	25.26	2451	28.64	2553	32.25		
18000	2089	9.90	1780	7.80	1872	10.04	1962	12.45	2048	14.98	2133	17.65	2220	20.49	2309	23.49	2400	26.67	2492	30.04				
19000	2194	11.29	1880	8.89	1968	11.27	2053	13.77	2135	16.39	2215	19.15	2294	22.03	2375	25.07	2459	28.30	2544	31.69				
20000	2299	12.80	1981	10.09	2066	12.62	2146	15.21	2225	17.95	2301	20.80	2375	23.75	2450	26.86	2526	30.10						
21000	2405	14.47	2082	11.40	2165	14.09																		

Performance Data

365 BEPL

Wheel Dia.: 36.50"

Max. BHP = 15.50 x (RPM ÷ 1000)³

CFM	1" SP		2" SP		3" SP		4" SP		5" SP		6" SP		7" SP		8" SP		9" SP		10" SP		11" SP		12" SP	
	RPM	BHP	RPM	BHP	RPM	BHP	RPM	BHP	RPM	BHP	RPM	BHP	RPM	BHP	RPM	BHP	RPM	BHP	RPM	BHP	RPM	BHP	RPM	BHP
9000	490	1.82																						
10000	502	1.96	680	4.56																				
12000	537	2.30	687	4.99	833	8.30																		
14000	580	2.73	708	5.49	837	8.92	961	12.81																
16000	630	3.27	740	6.13	853	9.62	966	13.67	1075	18.11														
18000	684	3.91	780	6.92	880	10.49	980	14.58	1081	19.20	1179	24.16	1272	29.28										
20000	741	4.68	825	7.83	914	11.49	1004	15.65	1094	20.27	1185	25.38	1274	30.81	1360	36.48								
22000	799	5.56	875	8.89	954	12.67	1036	16.93	1118	21.64	1200	26.76	1282	32.27	1364	38.18	1443	44.26	1520	50.53				
24000	857	6.54	928	10.10	999	14.03	1073	18.38	1148	23.16	1223	28.33	1298	33.88	1374	39.88	1449	46.15	1523	52.71	1595	59.45	1665	66.28
26000	917	7.69	983	11.46	1048	15.57	1115	20.04	1184	24.92	1253	30.17	1322	35.78	1391	41.72	1461	48.11	1531	54.82	1600	61.77	1668	68.97
28000	978	9.00	1040	13.01	1099	17.24	1160	21.86	1224	26.89	1286	32.23	1352	37.93	1416	43.94	1481	50.37	1545	57.04	1610	64.11	1675	71.49
30000	1039	10.45	1097	14.68	1153	19.15	1209	23.91	1267	29.03	1327	34.53	1387	40.34	1446	46.38	1506	52.82	1566	59.55	1626	66.59	1687	74.06
32000	1101	12.10	1155	16.53	1208	21.21	1261	26.20	1314	31.44	1369	37.03	1425	42.94	1481	49.13	1537	55.65	1593	62.44	1650	69.63	1706	76.98
34000	1163	13.92	1214	18.58	1265	23.52	1314	28.65	1364	34.09	1414	39.75	1466	45.76	1519	52.11	1572	58.73	1625	65.66	1677	72.73		
36000	1225	15.93	1274	20.84	1322	25.99	1369	31.35	1415	36.89	1462	42.73	1511	48.94	1560	55.35	1610	62.08	1660	69.08	1710	76.37		
38000	1288	18.17	1334	23.29	1380	28.68	1425	34.26	1469	40.03	1513	46.03	1558	52.32	1604	58.87	1651	65.72	1698	72.79				
40000	1351	20.62	1395	25.99	1439	31.61	1482	37.42	1524	43.40	1565	49.51	1608	56.03	1651	62.72	1695	69.69						
42000	1414	23.29	1456	28.90	1498	34.74	1539	40.76	1579	46.93	1619	53.32	1659	59.92	1699	66.71								
44000	1478	26.25	1518	32.09	1558	38.16	1597	44.37	1636	50.81	1674	57.38	1712	64.15										

Maximum RPM @ 70°F:

Class II — 1283

Class III — 1272

Must derate for temperature and plug wall thickness.

402 BEPL

Wheel Dia.: 40.25"

Max. BHP = 25.30 x (RPM ÷ 1000)³

CFM	1" SP		2" SP		3" SP		4" SP		5" SP		6" SP		7" SP		8" SP		9" SP		10" SP		11" SP		12" SP	
	RPM	BHP	RPM	BHP	RPM	BHP	RPM	BHP	RPM	BHP	RPM	BHP	RPM	BHP	RPM	BHP	RPM	BHP	RPM	BHP	RPM	BHP	RPM	BHP
12000	454	2.36	616	5.49																				
14000	478	2.68	620	5.92																				
16000	509	3.09	632	6.38	757	10.56																		
18000	544	3.58	653	6.98	763	11.15	873	16.04																
20000	582	4.14	679	7.66	778	11.91	878	16.86	976	22.36														
22000	623	4.80	709	8.46	799	12.79	889	17.75	980	23.35	1069	29.43	1153	35.66										
24000	665	5.56	743	9.38	825	13.82	907	18.84	990	24.46	1074	30.71	1155	37.25	1233	44.05								
26000	708	6.41	779	10.39	854	14.97	930	20.09	1006	25.74	1083	31.98	1160	38.72	1235	45.76	1308	53.11						
28000	751	7.34	818	11.55	886	16.25	956	21.45	1027	27.89	1098	33.48	1169	40.21	1241	47.50	1311	55.03	1379	62.82	1446	70.87		
30000	796	8.42	858	12.81	920	17.64	986	23.04	1052	28.89	1118	35.21	1184	41.97	1250	49.17	1317	56.91	1383	64.95	1448	73.33	1510	81.69
32000	840	9.58	899	14.20	957	19.21	1017	24.68	1079	30.65	1141	37.07	1203	43.92	1265	51.19	1327	58.87	1390	67.08	1452	75.55	1513	84.29
34000	886	10.92	942	15.77	996	20.95	1051	26.53	1109	32.63	1167	39.11	1225	46.02	1284	53.43	1342	61.12	1401	69.34	1460	77.94	1519	86.91
36000	931	12.34	984	17.40	1036	22.82	1088	28.61	1141	34.77	1196	41.40	1251	48.42	1306	55.85	1361	63.64	1416	71.80	1471	80.33	1527	89.38
38000	977	13.93	1028	19.25	1077	24.85	1125	30.74	1175	37.08	1227	43.88	1279	51.00	1331	58.50	1383	66.37	1435	74.59	1487	83.15	1540	92.24
40000	1023	15.65	1071	21.17	1119	27.06	1165	33.17	1211	39.58	1259	46.43	1309	53.77	1358	61.31	1408	69.37	1457	77.62	1507	86.36	1556	95.26
42000	1070	17.57	1116	23.34	1161	29.39	1205	35.70	1249	42.32	1294	49.31	1340	56.64	1387	64.36	1434	72.40	1482	80.96	1529	89.69		
44000	1116	19.60	1160	25.59	1204	31.92	1246	38.43	1288	45.24	1330	52.32	1374	59.87	1418	67.65	1463	75.83	1508	84.33	1553	93.18		
46000	1163	21.84	1205	28.05	1247	34.59	1288	41.37	1328	48.36	1368	55.62	1409	63.24	1451	71.20	1494	79.55	1537	88.16				
48000	1210	24.26	1251	30.75	1291	37.49	1330	44.44	1368	51.58	1407	59.11	1446	66.90	1485	74.89	1526	83.39						

Maximum RPM @ 70°F:

Class II — 1163

Class III — 1566

Must derate for temperature and plug wall thickness.

445 BEPL

Wheel Dia.: 44.50"

Max. BHP = 41.80 x (RPM ÷ 1000)³

CFM	1" SP		2" SP		3" SP		4" SP		5" SP		6" SP		7" SP		8" SP		9" SP		10" SP		11" SP		12" SP	
	RPM	BHP	RPM	BHP	RPM	BHP	RPM	BHP	RPM	BHP	RPM	BHP	RPM	BHP	RPM	BHP	RPM	BHP	RPM	BHP	RPM	BHP	RPM	BHP
14000	406	2.80																						
16000	422	3.10	559	7.03																				
18000	442	3.45	564	7.44	683	12.38																		
20000	466	3.89	575	7.94	685	13.02																		
22000	492	4.37	591	8.55	690	13.62	789	19.56																
24000	520	4.92	610	9.23	701	14.39	793	20.43	882	27.05														
26000	550	5.57	631	9.97	715	15.21	800	21.30	885	28.14	966	35.37												
28000	581	6.29	655	10.84	733	16.20	811	22.28	890	29.16	968	36.62	1043	44.46										
30000	612	7.06	681	11.80	753	17.26	826	23.45	899	30.31	973	37.92	1046	46.08	1115	54.38								
32000	644	7.93	708	12.83	775	18.44	843	24.69	912	31.67	980	39.18	1050	47.52	1118	56.22	1183	65.11	1247	74.34				
34000	676	8.87	737	14.00	798	19.67	863	26.11	927	33.10	992	40.78	1056	48.92	1122	57.89	1186	67.15	1247	76.52	1308	86.37		
36000	709	9.93	766	15.22	824	21.12	884	27.60	945	34.73	1006	42.45	1067	50.72	1128	59.53	1189	68.86	1250	78.74	1309	88.85	1366	99.04
38000	742	11.07	796	16.56	850	22.57	907	29.25	964	36.40	1022	44.23	1080	52.59	1137	61.33	1196	70.91	1254	80.81	1311	91.04	1367	101.61
40000	775	12.29	827	18.02	878	24.21	931	30.99	986	38.37	1040	46.16	1095	54.59	1150	63.52	1205	72.97	1260	82.89	1316	93.48	1370	104.15
44000	842	15.08	890	21.27	937	27.89	984	34.97	1032	42.50	1082	50.64	1131	59.11	1181	68.22	1231	77.78	128					

Performance Data

490 BEPL

Wheel Dia.: 49.00"

Max. BHP = 67.60 x (RPM ÷ 1000)³

CFM	1" SP		2" SP		3" SP		4" SP		5" SP		6" SP		7" SP		8" SP		9" SP		10" SP		11" SP		12" SP	
	RPM	BHP	RPM	BHP	RPM	BHP	RPM	BHP	RPM	BHP	RPM	BHP	RPM	BHP	RPM	BHP	RPM	BHP	RPM	BHP	RPM	BHP	RPM	BHP
16000	364	3.25																						
18000	374	3.53	506	8.19																				
20000	387	3.84	508	8.62																				
22000	403	4.22	513	9.08	620	15.05																		
24000	420	4.63	521	9.56	622	15.72																		
26000	440	5.13	532	10.13	625	16.31	716	23.42																
28000	461	5.67	545	10.75	632	17.04	718	24.27	801	32.23														
32000	505	6.91	577	12.27	653	18.72	728	26.02	804	34.31	878	43.27												
36000	551	8.39	614	14.08	681	20.72	748	28.22	815	36.53	883	45.77	949	55.50	1013	65.70								
40000	599	10.16	656	16.26	714	23.08	774	30.73	835	39.28	895	48.43	956	58.45	1017	69.19	1075	80.07	1136	95.93				
44000	648	12.22	700	18.72	751	25.78	806	33.78	860	42.31	915	51.67	970	61.70	1025	72.40	1081	83.94	1136	95.93	1189	108.13	1240	120.38
48000	697	14.55	746	21.54	792	28.93	841	37.14	891	45.98	941	55.47	991	65.58	1042	76.50	1092	87.83	1143	99.97	1194	112.71	1244	125.80
52000	748	17.31	793	24.71	836	32.54	880	41.01	925	50.05	971	59.71	1018	70.19	1064	81.04	1111	92.69	1157	104.66	1204	117.46	1251	130.79
56000	799	20.42	840	28.18	881	36.50	921	45.23	962	54.55	1005	64.60	1048	75.14	1091	86.25	1134	97.92	1177	110.09	1220	122.79	1263	136.01
60000	850	23.89	889	32.17	927	40.85	965	50.07	1002	59.58	1041	69.82	1081	80.63	1121	91.90	1161	103.70	1202	116.31	1242	129.13	1282	142.42
64000	901	27.77	938	36.52	974	45.67	1010	55.32	1045	65.28	1080	75.63	1117	86.72	1154	98.18	1192	110.31	1230	122.96	1267	135.81		
68000	953	32.16	988	41.40	1022	50.99	1056	61.05	1089	71.40	1122	82.16	1156	93.50	1190	105.14	1226	117.65	1261	130.28				
72000	1005	37.02	1038	46.71	1071	56.86	1103	67.31	1134	78.02	1165	89.12	1197	100.83	1229	112.88								
76000	1057	42.37	1089	52.63	1120	63.18	1150	73.98	1180	85.19	1210	96.83	1239	108.59	1269	120.95								

Maximum RPM @ 70°F:

Class II — 956

Class III — 1286

Must derate for temperature and plug wall thickness.

Dimensional Data – Accessories

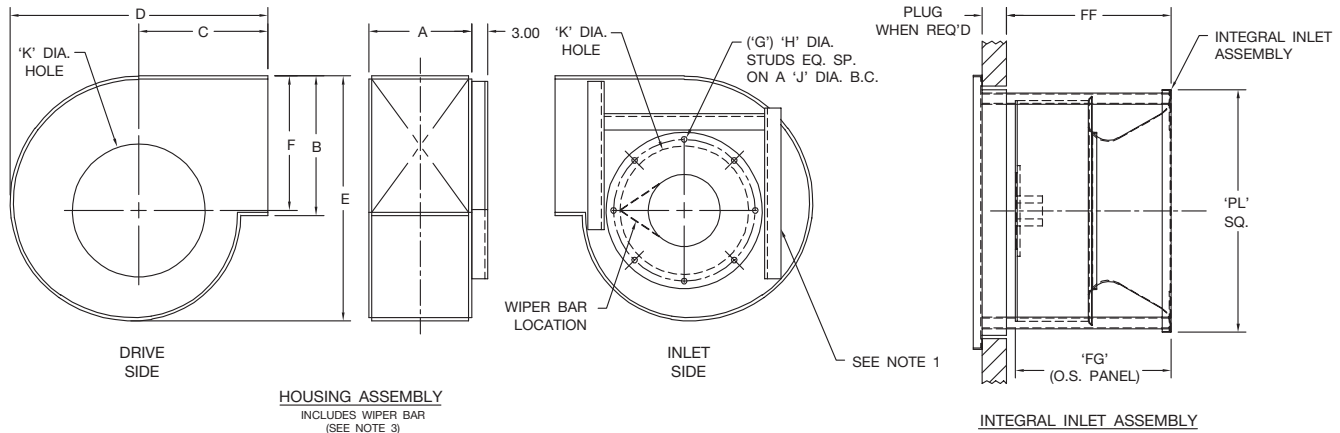

NOTES:

- Inlet side frame angle on sizes 402, 445, and 490 only.
- CW rotation is shown. CCW is similar but opposite.
- Wiper bar mounted on inlet cone when TCF housing is supplied. Orient with respect to discharge as shown. Not supplied with spark resistant construction. Wiper bar is required to prevent re-circulation of air.
- Dimensions shown are in inches unless otherwise indicated.

SIZE	A		B		C	D		E		F		G	H	J	K	PL	FF	FG
	CL 2	CL 3	CL 2	CL 3		CL 2	CL 3	CL 2	CL 3	CL 2	CL 3							
122	10.00	10.00	13.81	13.81	12.56	25.13	25.13	23.69	23.69	13.19	13.19	8	3/8 - 16	15.88	14.13	19.25	10.13	8.63
150	11.00	11.00	15.63	15.63	13.69	27.88	27.88	26.69	26.69	14.88	14.88	8	3/8 - 16	17.63	15.94	19.25	11.19	9.69
165	12.19	12.19	17.56	17.56	14.81	30.81	30.81	30.00	30.00	16.75	16.75	8	3/8 - 16	19.59	17.88	26.00	12.44	10.94
182	14.31	14.44	19.38	19.50	14.00	29.69	29.75	33.13	33.25	19.31	19.38	8	3/8 - 16	21.00	19.50	26.00	14.50	13.00
200	15.63	15.75	21.19	21.31	15.31	32.63	32.69	36.31	36.44	21.13	21.19	8	3/8 - 16	23.38	21.38	26.00	15.81	14.31
222	17.19	17.31	23.56	23.69	17.19	36.25	36.31	40.31	40.44	23.50	23.56	8	3/8 - 16	25.50	23.75	28.25	17.31	15.81
245	18.88	19.00	26.06	26.19	19.00	40.06	40.13	44.50	44.63	25.94	26.00	8	3/8 - 16	27.75	27.00	28.25	19.00	17.50
270	20.63	20.75	28.75	28.88	20.94	44.19	44.25	49.13	49.25	28.63	28.69	16	3/8 - 16	29.75	29.00	32.13	20.75	19.25
300	22.63	22.75	31.88	32.00	23.31	49.06	49.13	54.50	54.63	31.75	31.81	16	3/8 - 16	33.63	31.63	32.13	22.81	21.31
330	24.81	24.94	35.19	35.31	25.75	54.13	54.19	60.06	60.19	35.06	35.13	16	3/8 - 16	37.25	34.75	38.88	24.94	23.44
365	27.31	27.44	38.75	38.88	28.50	60.00	60.06	66.38	66.50	38.63	38.69	16	3/8 - 16	40.75	39.50	38.88	27.44	25.94
402	29.94	30.06	42.69	42.81	31.50	66.19	66.25	73.13	73.25	42.56	42.63	16	3/8 - 16	44.13	42.50	48.25	30.13	28.63
445	32.94	33.06	47.19	47.31	34.88	73.13	73.19	80.81	80.94	57.06	57.13	16	3/8 - 16	48.63	47.25	48.25	33.13	31.63
490	36.06	36.19	52.00	52.13	38.50	80.69	80.75	89.06	89.19	61.88	61.94	16	3/8 - 16	53.13	52.00	52.00	36.25	34.75

AC1001437

Dimensions are not to be used for construction. Certified drawings are available upon request.

Dimensional Data – Class II

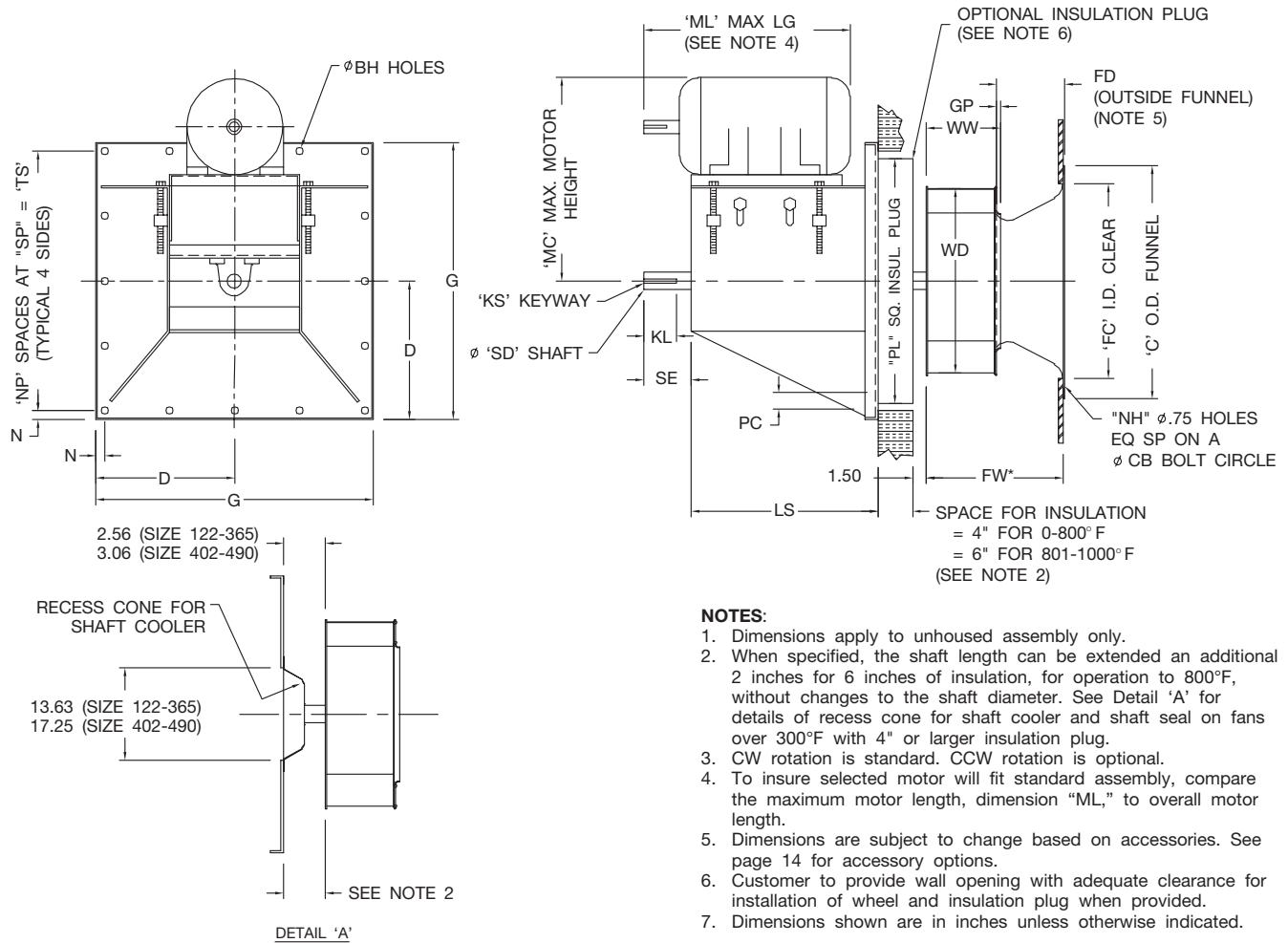

- NOTES:**
1. Dimensions apply to unhoused assembly only.
 2. When specified, the shaft length can be extended an additional 2 inches for 6 inches of insulation, for operation to 800°F, without changes to the shaft diameter. See Detail 'A' for details of recess cone for shaft cooler and shaft seal on fans over 300°F with 4" or larger insulation plug.
 3. CW rotation is standard. CCW rotation is optional.
 4. To insure selected motor will fit standard assembly, compare the maximum motor length, dimension "ML," to overall motor length.
 5. Dimensions are subject to change based on accessories. See page 14 for accessory options.
 6. Customer to provide wall opening with adequate clearance for installation of wheel and insulation plug when provided.
 7. Dimensions shown are in inches unless otherwise indicated.

SIZE	BH	C	CB	D	FC	FD	FR	FW	G	GP	KL	KS	LS
122	0.56	15.75	14.75	11.38	13.25	4.38	213T	8.48	22.75	0.25	4.00	.38x.19	17.50
150	0.56	18.25	17.25	11.38	16.19	5.38	215T	9.55	22.75	0.25	4.00	.38x.19	18.50
165	0.56	20.00	19.00	14.81	17.75	5.94	215T	10.75	29.63	0.25	4.00	.38x.19	18.50
182	0.56	22.00	21.00	14.81	19.50	6.56	254T	12.84	29.63	0.38	4.50	.50x.25	21.00
200	0.56	24.38	23.38	14.81	21.38	7.19	254T	14.12	29.63	0.41	4.50	.50x.25	21.00
222	0.56	26.63	25.50	16.00	23.75	8.00	256T	15.67	32.00	0.45	4.50	.50x.25	22.50
245	0.56	28.63	27.75	16.00	27.00	8.81	256T	17.31	32.00	0.50	4.50	.50x.25	22.50
270	0.69	31.00	29.75	18.31	29.00	9.69	284T	19.05	36.63	0.55	5.00	.50x.25	23.00
300	0.69	34.88	33.63	18.31	31.62	10.75	284T	21.07	36.63	0.61	5.00	.50x.25	23.00
330	0.69	38.50	37.25	21.81	34.75	11.81	286T	23.22	43.63	0.67	5.00	.50x.25	24.50
365	0.69	42.00	40.75	21.81	39.50	13.06	286T	25.71	43.63	0.75	5.50	.50x.25	24.50
402	0.69	45.38	44.13	27.50	42.50	14.44	326T	28.38	55.00	0.82	5.50	.50x.25	27.50
445	0.69	49.88	48.63	27.50	47.25	15.94	326T	31.36	55.00	0.91	5.50	.63x.31	27.50
490	0.69	54.38	53.13	27.50	52.00	17.56	326T	34.47	55.00	1.00	5.50	.63x.31	27.50

SIZE	MC	ML	N	NH	NP	PC	PL	SD	SE	SP	TS	WD	WW
122	24.25	19.13	1.00	8	4	1.75	19.25	1.687	5.00	5.19	20.75	12.40	5.07
150	24.25	20.13	1.00	8	4	1.75	19.25	1.687	5.00	5.19	20.75	13.98	5.67
165	24.25	20.13	1.06	8	4	1.81	26.00	1.687	5.00	6.88	27.50	15.75	6.34
182	27.50	24.13	1.06	8	4	1.81	26.00	1.937	5.50	6.88	27.50	18.25	6.74
200	27.50	24.13	1.06	8	4	1.81	26.00	1.937	5.50	6.88	27.50	20.00	7.43
222	27.50	25.50	1.13	8	4	1.88	28.25	1.937	5.50	7.44	29.75	22.25	8.21
245	27.50	25.50	1.13	8	4	1.88	28.25	1.937	5.50	7.44	29.75	24.50	9.11
270	29.50	26.63	1.25	8	6	2.25	32.13	2.187	6.00	5.69	34.13	27.00	10.02
300	29.50	26.63	1.25	16	6	2.25	32.13	2.187	6.00	5.69	34.13	30.00	11.06
330	29.50	28.13	1.38	16	6	2.38	38.88	2.187	6.00	6.81	40.88	33.00	12.18
365	29.50	28.13	1.38	16	6	2.38	38.88	2.187	6.50	6.81	40.88	36.50	13.50
402	33.00	31.25	1.25	16	6	3.38	48.25	2.187	6.50	8.75	52.50	40.25	14.89
445	33.00	31.25	1.25	16	6	3.38	48.25	2.437	6.50	8.75	52.50	44.50	16.43
490	33.00	31.25	1.25	16	6	2.50	52.00	2.437	6.50	8.75	52.50	49.00	18.04

AC1001435

Dimensions are not to be used for construction. Certified drawings are available upon request.

Dimensional Data – Class III

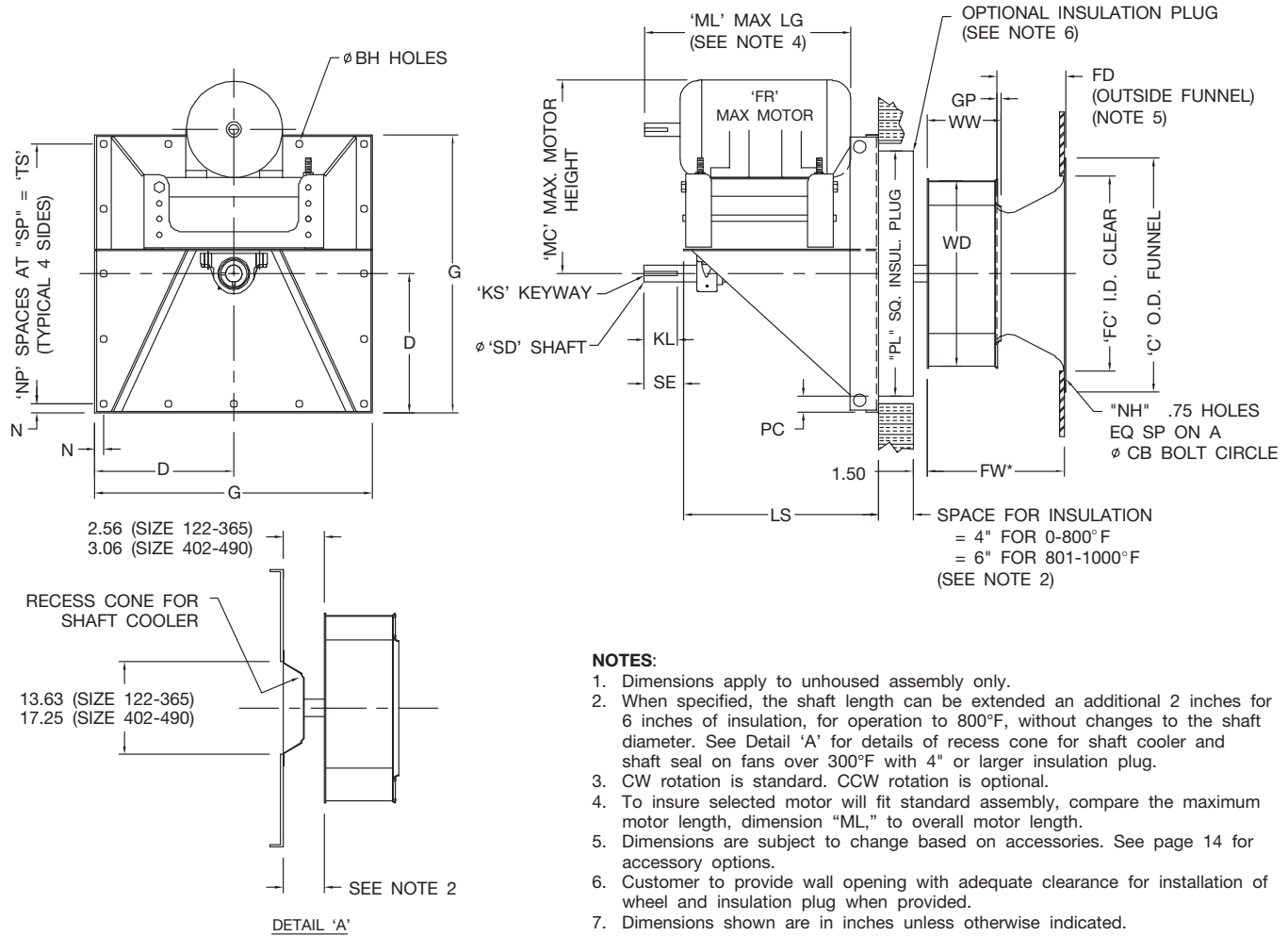

SIZE	BH	C	CB	D	FC	FD	FR	FW	G	GP	KL	KS	LS
182	0.56	22.00	21.00	14.81	19.50	6.56	256T	12.84	29.63	0.38	4.50	.63x.31	25.00
200	0.56	24.38	23.38	14.81	21.38	7.19	284T	14.12	29.63	0.41	5.50	.63x.31	27.50
222	0.56	26.63	25.50	16.00	23.75	8.00	286T	15.67	32.00	0.45	5.50	.63x.31	27.50
245	0.56	28.63	27.75	16.00	27.00	8.81	324T	17.31	32.00	0.50	6.00	.63x.31	30.50
270	0.69	31.00	29.75	18.31	29.00	9.69	326T	19.05	36.63	0.55	6.00	.63x.31	30.63
300	0.69	34.88	33.63	18.31	31.63	10.75	326T	21.07	36.63	0.61	6.00	.63x.31	30.63
330	0.69	38.50	37.25	21.81	34.75	11.81	365T	23.22	43.63	0.67	6.50	.63x.31	32.38
365	0.69	42.00	40.75	21.81	39.50	13.06	405T	25.71	43.63	0.75	8.00	.63x.31	37.88
402	0.69	45.38	44.13	27.50	42.50	14.44	405T	28.38	55.00	0.82	8.00	.63x.31	38.38
445	0.69	49.88	48.63	27.50	47.25	15.94	405T	31.36	55.00	0.91	8.00	.88x.44	38.38
490	0.69	54.38	53.13	27.50	52.00	17.56	405T	34.47	55.00	1.00	8.00	.88x.44	38.38

SIZE	MC	ML	N	NH	NP	PC	PL	SD	SE	SP	TS	WD	WW
182	26.50	25.75	1.06	8	4	1.81	26.00	2.437	4.50	6.88	27.50	18.25	6.74
200	28.00	28.88	1.06	8	4	1.81	26.00	2.437	5.50	6.88	27.50	20.00	7.43
222	28.00	32.00	1.13	8	4	1.88	28.25	2.687	5.50	7.44	29.75	22.25	8.21
245	32.00	32.00	1.13	8	4	1.88	28.25	2.687	6.00	7.44	29.75	24.50	9.11
270	32.00	32.00	1.25	8	6	2.25	32.13	2.687	6.00	5.69	34.13	27.00	10.02
300	32.00	32.00	1.25	16	6	2.25	32.13	2.687	6.00	5.69	34.13	30.00	11.06
330	34.00	34.38	1.38	16	6	2.38	38.88	2.687	6.50	6.81	40.88	33.00	12.18
365	38.00	41.25	1.38	16	6	2.38	38.88	2.687	8.00	6.81	40.88	36.50	13.50
402	38.00	41.25	1.25	16	6	3.38	48.25	2.937	8.00	8.75	52.50	40.25	14.89
445	38.00	41.25	1.25	16	6	3.38	48.25	3.437	8.00	8.75	52.50	44.50	16.43
490	38.00	41.25	1.25	16	6	2.50	52.00	3.437	8.00	8.75	52.50	49.00	18.04

AC1001436

Dimensions are not to be used for construction. Certified drawings are available upon request.

Belt Centers

MOTOR FRAME SIZE	CLASS II								CLASS III													
	122-165		182-245		270-365		402-490		182		200-222		245-300		300		365-402		445-490			
	MIN	MAX	MIN	MAX	MIN	MAX	MIN	MAX	MIN	MAX	MIN	MAX	MIN	MAX	MIN	MAX	MIN	MAX	MIN	MAX		
56	13	16.5	14	17.5	14.5	18	16	19.5	9.4	13.4	9.4	13.4	9.3	13.3	9.3	13.3	9.3	13.3	9.3	13.3	9.8	13.8
143-145	13	16.5	14	17.5	14.5	18	16	19.5	9.4	13.4	9.4	13.4	9.3	13.3	9.3	13.3	9.3	13.3	9.3	13.3	9.8	13.8
182-184	14	17.5	15	18.5	15.5	19	17	20.5	10.4	14.4	10.4	14.4	10.3	14.3	10.3	14.3	10.3	14.3	10.3	14.3	10.8	14.8
213-215	14.8	18.3	15.8	19.3	16.3	19.8	17.8	21.3	11.2	15.2	11.2	15.2	11	15	11.1	15.1	11.1	15.1	11.1	15.1	11.6	15.6
254-256	—	—	16.8	20.3	17.3	20.8	18.8	22.3	14.8	18.8	14.8	18.8	14.6	18.6	14.7	18.7	14.7	18.7	14.7	18.7	15.2	19.2
284-286	—	—	—	—	18	21.5	19.5	23	—	—	15.6	19.6	15.4	19.4	15.4	19.4	15.4	19.4	15.4	19.4	15.9	19.9
324-326	—	—	—	—	—	—	20.5	24	—	—	—	—	17.6	22.6	17.6	22.6	17.6	22.6	17.6	22.6	18.1	23.1
364-365	—	—	—	—	—	—	—	—	—	—	—	—	—	—	18.6	23.6	18.6	23.6	18.6	23.6	19.1	24.1
404-405	—	—	—	—	—	—	—	—	—	—	—	—	—	—	—	—	20.8	25.8	20.8	25.8	21.3	26.3

Typical Specifications

Fans shall be Type BEPL Single Thickness Airfoil, as manufactured by Twin City Fan & Blower, Minneapolis, Minnesota.

PERFORMANCE — Fans shall be tested and rated in accordance with industry accepted test codes and shall be guaranteed by the manufacturer to deliver rated published performance levels.

PLUG PANEL — Plug panel shall be of minimum 7 gauge steel with formed flanges to maintain flatness and rigidity. Panel shall be prepunched for bolt mounting. The "Cross Frame" bearing support shall be designed for maximum stability and load spreading. Bearings shall be serviceable without disassembly of panel or frame. Plug assembly is available for both horizontal and vertical application. Horizontal construction is standard. Vertical construction must be specified.

WHEEL — BEPL wheels shall be backward curved, non-overloading, single thickness airfoil type, designed for maximum efficiency and quiet operation. Wheels shall be constructed of heavy gauge steel, continuously welded to a flat wheel cone and backplate. Partial welding will not be acceptable.

SHAFT — Shafts shall be AISI 1040 or 1045 hot rolled steel accurately turned, ground, polished, and ring gauged for accuracy. Shafts shall be sized for a first critical speed of at least 1.43 times the maximum speed for the class.

BEARINGS — Bearings shall be either ball or spherical roller, heavy duty, self-aligning, pillow block type. Bearing selection is based upon L-10 minimum life of 40,000 hours or L-50 minimum life of 200,000 hours.

OPTIONAL ALL WELDED HOUSING — Housing shall be of heavy gauge steel. Housing shall be provided with wheel opening on each side and weld studs on inlet side for cone mounting. Specify rotation and discharge as viewed from drive side to insure proper stud placement. Housing supports and attachments for wall mounting to be provided by others.

ADJUSTABLE MOTOR BASE — Adjustable motor base is standard and shall have a four point leveling and tension adjustment to insure proper drive belt alignment. The motor base shall be heavy gauge steel and prepunched to accept standard motor frame specified.

OPTIONAL INLET VANES — Inlet vane blades are cantilever design or with centered supports equipped with permanently lubricated needle bearings and ball joints for smooth and easy operation. Vane assemblies are external type for sizes 122 through 165 and nested for sizes 182 through 490. Standard inlet vanes are applicable to 300°F. Consult factory for higher temperatures.

FACTORY RUN TEST — All fans prior to shipment shall be completely assembled and test run as a unit at the specified operating speed or maximum RPM allowed for the particular construction type. Each wheel shall be statically and dynamically balanced in accordance with ANSI/AMCA 204-96 "Balance Quality and Vibration Levels for Fans" to Fan Application Category BV-3, Balance Quality Grade G6.3. Balance readings shall be taken by electronic type equipment in the axial, vertical, and horizontal directions on each of the bearings. Records shall be maintained and a written copy shall be available upon request.

GUARANTEE — The manufacturer shall guarantee the workmanship and materials for its BEPL Single Blade Airfoil Plug Fans for at least one (1) year from startup or eighteen (18) months from shipment, whichever occurs first. Fans shall be Type BEPL Single Thickness Airfoil, as manufactured by Twin City Fan & Blower, Minneapolis, Minnesota.